

Rocket Propulsion Engineering Company Small Launch Vehicle

James Grote and Tom Pavia
Rocket Propulsion Engineering Company
PO Box 1056, Mojave CA 93502

Abstract

Rocket Propulsion Engineering (RPe) is developing the first in a family of two low-cost, two stage, small rocket vehicles suitable for target, suborbital, and small-sat orbital applications.

The first of these two launch vehicles, the Prospect LV-1 will have an orbital payload of 300-400 lb. The larger vehicle, the Prospect LV-2, uses about 80% of the components and technology of the LV-1 and will orbit payloads of 1500-1700 lb.

Two engines are being developed. A first stage 30,000 lbf class engine (R1-30L) and a second stage engine of approximately 2400 lbf (R1-2H). The engine designs are essentially identical except for size. Propellants are hydrogen peroxide/kerosene. The engines are ablatively cooled with additional film cooling. Chamber pressure is approximately 715 PSIA. Both engines use centrifugal turbopumps driven by an open cycle, bipropellant gas generator.

Medium-technology pump-fed rockets have significant advantages over pressure fed alternatives, provided the pump technology remains simple. Among these advantages are: smaller, lighter, more efficient engines; less propellant use; and simpler and smaller ground-handling equipment.

Most importantly, propellant tank structure is lighter and much simpler to engineer and manufacture, and high-pressure helium tankage is greatly reduced. RPe therefore decided to put the engineering effort into developing the turbopump rather than pressure-fed vehicle structures.

To be practical and cost effective, the turbopump must be simple by modern rocket engine standards. To this end, RPe has been pursuing a very modular, scalable pump design, utilizing as few components as possible – all components being readily available through standard commercial supply and manufacturing processes. The result is a very simple, very low-cost pump design that significantly enhances the overall vehicle design and greatly reduces vehicle structural weight and propellant requirements.

Vehicle structure employs weight-saving features such as the use of a common propellant tank bulkhead and the extensive use of modern composites. Storable, ambient temperature propellants eliminate many of the material, embrittlement, and strain-related design problems that typically accompany cryogenic vehicles.

The engines for these vehicles, especially the smaller R1-2H, should also be attractive candidates for use as the main propulsion engines on orbital transfer upper stages and as storable spacecraft engines.

Background

Rocket Propulsion Engineering Company (RPe) was formed to provide rocket engine and rocket vehicle design, test and development engineering services for small orbital and suborbital rocket vehicle projects. RPe personnel have worked on numerous rocket and aerospace projects over the last twenty years, splitting time about half between entrepreneurial rocket startups and aerospace majors, including Lockheed and Rocketdyne.

Company principals' recent responsibilities include the design and operation of large (>100,000 lbf) high-pressure (>4500 PSI) liquid oxygen-kerosene rocket engine test facilities; a plant used to produce tons of concentrated hydrogen peroxide for a manned flight program; and the design and fabrication of rocket engine systems, including fly-by-wire rocket engine controls, for Rotary Rocket Company's successfully flown manned Atmospheric Test Vehicle.

RPe is currently developing the Prospect light-sat launch vehicle.

Introduction

Rocket Propulsion Engineering Company for the past nine months has been developing the first of a modular family of small liquid-fueled rocket vehicles. These vehicles are targeted specifically to serve as small satellite launchers and, in their single stage versions, as sounding and target rockets. Two vehicles are in development, with orbital payloads of 400 lb and 1600 lb, respectively (150 nm, 38 degrees easterly). The technologies of these two

vehicles are identical, and the large vehicle uses the same engines, avionics, software and in general about 80% of the components of the small vehicle.

Our rockets are designed with a mixture of low and high-technology components, almost all of them commercially available or products of conventional machining operations. The result of this effort, we believe, is modern, compact, ultralight, very low-cost launch vehicles, optimized for their roles. These vehicles have a number of features, which taken together make them representatives of the next generation of launch-vehicle technology:

- Simple, efficient, low-technology pump fed engines
- Non-toxic, ambient temperature, high density propellants
- All composite (plastic) airframes
- Commercial industrial electronics
- Very low cost manufacture and operations

Engine Description

RPe is developing two versions of our basic engine for the initial two-stage launch vehicle. These include the R1-30 and the R1-2, of approximately 30,000 lbf and 2400 lb, respectively. The engine designs are essentially identical except for size.

Propellants. Oxidizer will be 89% hydrogen peroxide for R1-30 engine and 95% for the smaller R1-2 engine. Fuel will be JP-4. These propellants simplify field operations, and impact engine design and operation, and vehicle tank design. They are readily available, transportable (in the lower concentration

of peroxide), storable, non-volatile and non-toxic. The propellant combination is dense and thus contributes to airframe tankage weight savings, with resultant high mass-fractions.

Maintaining fuel and oxidizer at the same temperature simplifies the job of engineering the propellant tanks. Fuel and oxidizer tanks share a common bulkhead, and the main oxidizer line runs directly through the fuel tank. These do not require insulation and are not subject to other problems seen with cryogenic propellants, such as thermal expansion-induced strain or condensation. The propellants can be stored in uninsulated tanks on site for months without significant loss or breakdown.

Engine Features. The R1 engines (Figure 1) are ablatively cooled with additional film cooling. Chamber pressure is approximately 715 psia. Both engines use centrifugal turbopumps driven by an open cycle, fuel-rich, bipropellant gas generator. Approximately 1% of the vehicle thrust is generated by the turbopumps.

Developing new rocket turbopumps is often seen as a prohibitive, costly challenge to a small program such as ours. This was our initial belief, until we began to look at the design and development effort in detail. There are two big advantages to pumps: they reduce vehicle bulk and weight resulting from pressurized tanks, and they allow the engine to operate at higher pressures than is normal for pressure-fed vehicles.

For the additional complexity of a pump we get a compensating array of benefits. Higher pressures lead to more compact

engines, higher thrust to weight and higher low-altitude ISP. The tank structure is easier to engineer and much easier to manufacture, the vehicles are much smaller and lighter, ground handling equipment and test stands are smaller and simpler, propellant storage is reduced, testing is cheaper and development mistakes can be repaired more quickly at less cost. Even simple pumps of moderate efficiency will provide these benefits.

Therefore we started with the goal of not pressing the state of the art in pump design, but rather producing as simple a turbopump as possible that would provide the required benefits. This meant reducing pump requirements to their bare minimums, and using as many commercially available components and ordinary (non-exotic) machine shop operations, as possible. We now have well over one thousand hours of engineering in the engine and turbopump systems. We have identified component suppliers, and machinists and fabricators for all significant components. The following chart (Table 1) summarizes our experience.

Table 1: Turbopump Fabrication Component Method

<u>Pump Component</u>	<u>Design and Fabr. Method</u>
Impeller	Standard Commercial
Inducer	Standard Commercial
Shaft	Standard Commercial
Housing	Standard Commercial
Bearings	Standard Commercial
Seals	Standard Commercial
Valves	Standard Commercial
Injector Components	Standard Commercial
Turbine	Std.Commercial/Custom

Of all turbopump components, only the turbine has proven to be a challenge for

standard commercial machining fabrication and may require the services of a specialized machine shop.

Key to the design of the turbopump has been to simplify it, even at the cost of some theoretical efficiency:

- Operating temperatures and pressures are low. Gas generator nominal temperatures and pressures have been kept modest (<1400 F, and 1200 PSI) by RPe standards (company personnel have worked routinely with high-pressure (>4500 PSI), high flow rate liquid oxygen /kerosene rocket engine systems).
- All spinning components are single stage.
- Rotational velocities are reasonable (<28,000 RPM).
- The turbopump operation is completely independent of the main engines. The gas generator has an independent propellant supply that is pressure fed using helium tanks that are also independent of the main tank pressurization system. The turbopump is non-bootstrapped and does not pump its own propellant, so the independent turbopump spinup start system, with its associated design and development costs, is eliminated.

Since the turbopump gas generator operates independently of the engine, design and testing complexities related to pump-engine interactions, present in the development of staged combustion cycle engines (for example), are eliminated. Development costs and uncertainties are reduced, since the

pump and engine can be developed and tested as separate projects. Pump start-up properties, once determined, can be mimicked on the pressure-fed engine stand, so when independent testing is complete, the systems can be mated with confidence.

The extra fuel, helium pressurant, tankage and associated plumbing result in a penalty, compared to a bootstrapped pump system, of about 103-lb in the first stage, and less in the upper stage. We were willing to pay this penalty for the great simplicity of the design and development effort, and the reduction in test time and costs.

Even with these minor weight increases over an optimum pump-fed system, the vehicle is significantly lighter and smaller than a corresponding pressure-fed vehicle of the same capacity. The combination of high-density ambient-temperature propellants and a simple, robust, efficient pump-fed engine simplifies the design and development of a very small, very light-weight structural airframe.

Prospect Launch Vehicle Description

The initial vehicle (Figure 3), the Prospect LV-1, has two stages, the first powered by a single R1-30L 30,000 lbf engine, and the second stage by the 2400 lbf R1-2U engine. The vehicle first stage is approximately 50 inches in diameter. The upper stage necks down through a conical interstage fairing to 42 inches. These sizes were determined, first of all, by the diameter of the spherical oxidizer tank required in the upper stage, and by structural considerations related to vehicle diameter and compression and bending loads, and ground handling

considerations, for the first stage. At 51 ft long the vehicle is very compact.

Structure. The Prospect LV-1 is fabricated largely of a honeycomb sandwich structure utilizing graphite-epoxy face sheets optimized to resist ground handling and flight operational loads. To the outer honeycomb layer is applied a thin sheet of proprietary external insulation. Except for nose and interstage heating, and base heating about the engine, thermal requirements are modest, and the core structure temperatures should not exceed 200 F. Overall wall thickness is about 0.288 in. We are still trading nose-cone fabrication methods, but are leaning toward the use of a reinforced sheet metal structure with foam sub-insulation.

Propellant Systems. All plumbing is internal to the structure, resulting in an exceptionally clean design. This includes oxidizer lines running through the fuel tank, as well as oxidizer and fuel tank pressurization lines coming up from the helium storage tanks located in the engine bay. With the exception of a modest electrical/signal cable run, which runs beneath the insulation, there are no conduits on the outside of the vehicle. No main power lines run outside; with the caveat that we have not yet attended to command-destruct system design, apart from assigning weight to it in the weight & balance spreadsheet.

The oxidizer tank is located above the fuel tank and shares a common uninsulated bulkhead. Both tanks contain slosh baffling, and are pressurized to maintain pump inlet pressure requirements, at 30 PSIA and 25 PSIA, respectively, for the oxidizer and fuel tanks. Both tanks are sealed

with a proprietary liner material and will allow the vehicle to be stored, unpressurized, in the upright position with propellants on board for a significant amount of time (weeks) with no trouble. Even unpressurized, upright storage will insure that positive pressure gradients remain between the oxidizer and fuel systems, important for safe storage.

Figure 1: R1-30L Rocket Engine.

The Prospect Launch Vehicle 1st stage engine is rated at 30,000-lbf sea-level takeoff thrust. Propellants are 89% hydrogen peroxide and kerosene. The engine uses a single-stage, open cycle gas-generator driven turbopump. Pump and engine systems have independent propellant tank and tank pressurization systems.

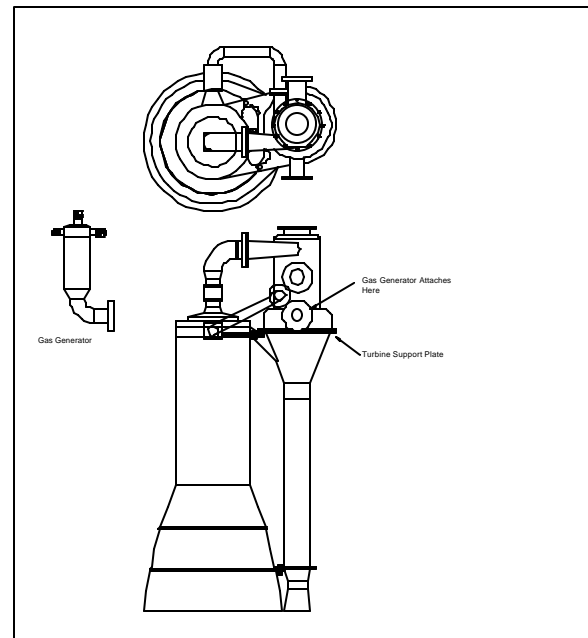

Propellant for the first stage gas generator is held in three small spherical fuel tanks and one oxidizer tank. In the second stage, two unequal sized tanks hold fuel and oxidizer. All gas generator tanks are filament-wrapped graphite-epoxy spheres pressurized to 1400 PSIA.

The vehicle uses helium for all pressurant requirements. There are two independent pressurant stores: main propellant tank pressurant, and the gas generator propellant tank pressurant. This separation optimizes the helium mass required, because of the radically different final helium tank pressures required for the two systems; about 80 PSI for the main propellant system, and about 1400 PSI for the gas generator pressurant. The latter tankage also supplies valve actuator gas, cold-gas for roll thrusters, gimbal actuation blowdown gas and staging separation thruster gas. The use of the excess gas generator helium pressure remaining at first stage burnout by stage separation thrusters takes advantage of a resource that otherwise would be wasted. Also, splitting the helium tank supplies into two groups was a penalty-free decision, since in any case we needed multiple small helium tanks to fit in the engine bay at the base of the vehicle.

Helium in the first stage is stored in a total of four filament-wrapped graphite-epoxy tanks pressurized to 4500 PSI; one helium tank for pressurizing the main propellant tanks; and three helium tanks for pressurizing the four gas generator propellant tanks and the other auxiliary systems mentioned just above. There are two helium tanks in the upper stage, one each for the main tank and GG system.

Engine steering is by means of gimbaling. We provide sufficient gimbal power for engine acceleration rates of 1 Rad/sec². The maximum gimbal angle is +/- 5 degrees (all azimuth). Thus maximum first stage side thrust will be on the order of 2600 lb.

Avionics. The Prospect LV-1 will use a single ruggedized flight computer located in the upper stage for all guidance and control tasks. Choice of IMU has not been made, but we are actively trading for one of several suitable missile inertial measurement systems. For precision orbit placement accuracy, top-end guidance units such as the Honeywell Space Integrated GPS/INS (SIGI) have been considered. They are expensive

Figure 2: The RPe Prospect LV-1 Launch Vehicle

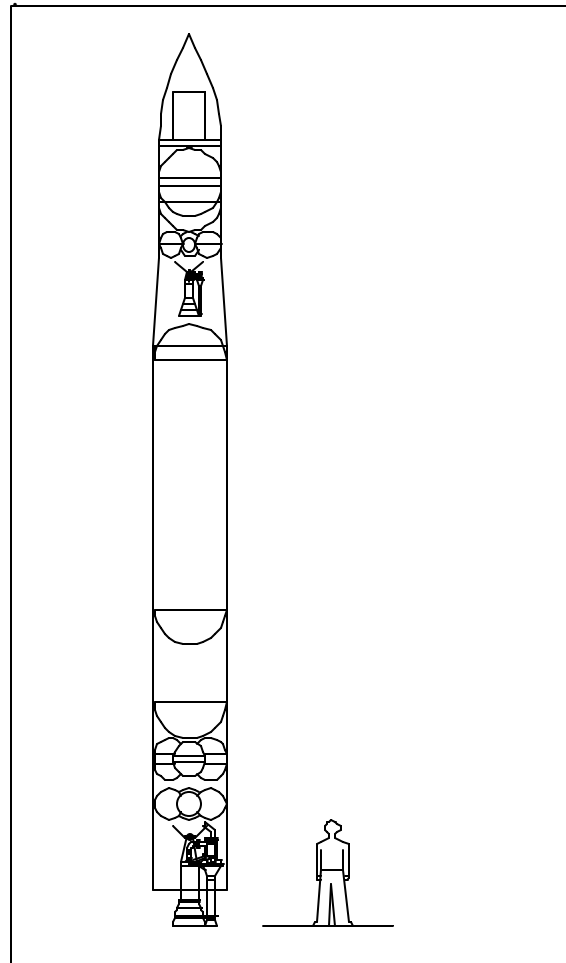

The flight computer selected is an almost-unmodified conformally-coated Power-PC industrial single-board

computer adhering to the Compact PCI 3U-bus standard. These computers are very compact, vibration resistant, and have gas-tight connectors and are available with digital and analog I/O cards conforming to the same standards. They are also very low cost. Typical mean time to failure of cards like these is measured in hundreds of thousands of hours. Moreover, space-rated, radiation-resistant, software and hardware plug-compatible versions are becoming available from Lockheed-Martin and other companies, so an upgrade path to latchup immune, radiation resistant hardware will be available for more advanced follow-on vehicles that require extended stays in space, or for vehicle operations at high orbital latitudes.

The flight computer in the second stage controls the first stage engine control electronics by means of a dual redundant message-passing serial bus to a single board microcontroller located in the first stage engine bay. This control method avoids the weight and complexity of running power or control lines the length of the vehicle.

Almost all powered components in each stage are located within four feet of the computers, power supplies, and batteries, thus limiting power and control line weights. All valves are latching (power off after switching) and in any case use little power (~10 Watts) each when powered.

Current baseline (subject to vacuum, thermal and vibration testing) for electric power are industrial lithium-ion batteries, with Nicad backups.

Performance

The Prospect LV-1 and LV-2 orbital payloads are 400 lb and 1600 lb, respectively, to 150 nm easterly at 38 degrees (Wallops Island). See Figure 4. Direct ascent trajectory with in-atmosphere gravity turn, followed by fixed pitch rate turn.

Vehicle Family

Two sounding, or target, vehicles created from first and second stage hardware are natural variations on the Prospect launch vehicle. An essentially unmodified first stage, forming the SV-1 will be the main offering. The SV-1 will also serve as a test stage used to confirm hardware, control and aerodynamic operation early in the Prospect development cycle. A somewhat more modified sea level version of the upper stage (SV-2) using the R1-2L engine will also be available.

The larger Prospect LV-2 will be offered after introduction of the LV-1. This vehicle will have four 30,000 lbf R1-30L engines in the first stage, and a single altitude version of that engine, the R1-10U in the upper stage. LV-2 performance is shown in Figure 4. The family of vehicles is shown in Figure 5.

Figure 4: Prospect LV-1 and LV-2 Performance

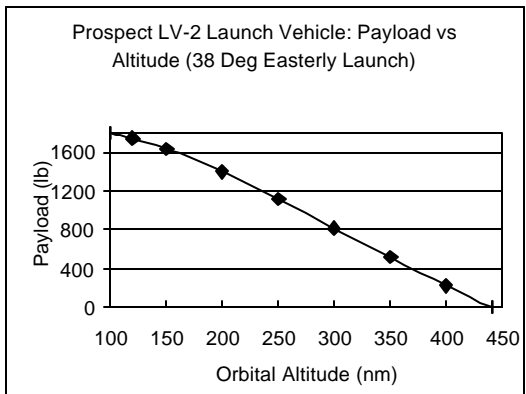
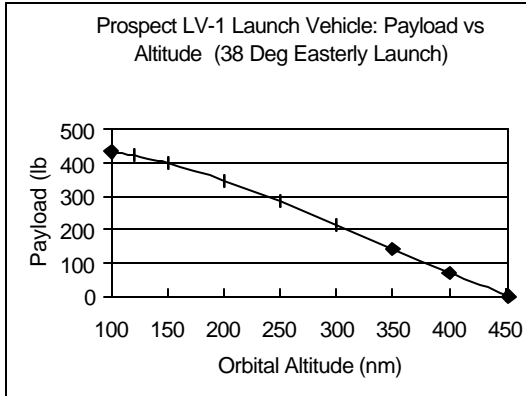
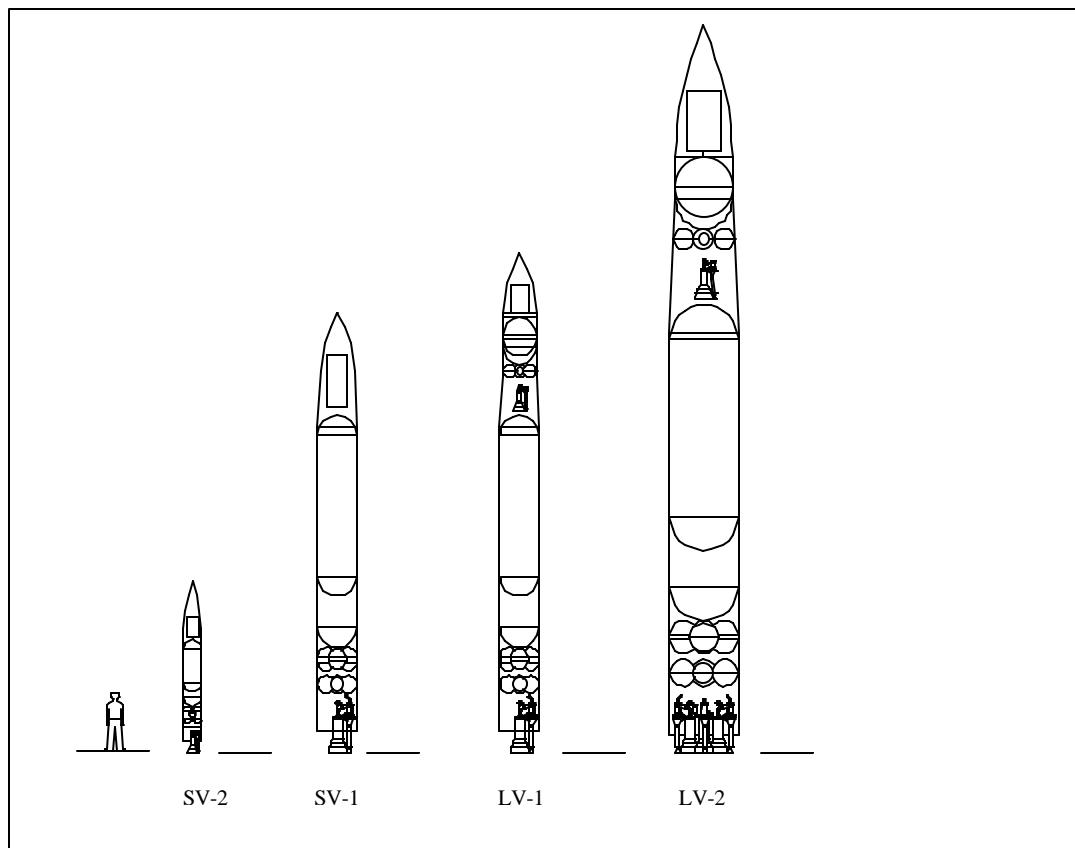

Figure 5: Prospect Family of Launch Vehicles. From left: Prospect SV-2 and SV-1 Sounding Rockets, 2000 lbf and 30,000 lbf takeoff thrust; Prospect LV-1 and LV-2 orbital launch vehicles will accommodate payloads of 300-400 lb, and 1500 – 1700 lb, respectively. See also Figure 4.



Launch Services. The Prospect LV-1 and LV-2 launch vehicles will provide launch services designed specifically for the requirements of small satellite launches. Launch customers will have the option of two vehicles that cover the payload ranges of satellites of this class.

Customers will be able to specify the launch date and orbital parameters. There will be no need to wait for a slot as ballast on a large vehicle launched at the wrong time going to the wrong destination, pay extra costs for oversized vehicles, or to accommodate to the demands of launch bureaucracies tuned to the needs of large, costly, complex satellite payloads.

The Prospect sounding rockets will provide alternative high-performance low-cost launches for suborbital payloads.

The Prospect vehicles are being designed for engineering, development and manufacturing cost savings, and launch prices will reflect these savings. We anticipate availability in 2003.